

KEN-NAN

AUTOMOTIVE EQUIPMENT

10,000 POUND TWO-COLUMN AUTOMOTIVE LIFT



Model: PRO-V10 Manual

**KEN-NAN
203 EAST LAKE RD
AIRDRIE, AB
403.287.3021
kennan.ab.ca**

Table of Contents

<u>Chapter/Paragraph</u>	<u>Page</u>
Registration.....	iii
Warranty	iv
Safety Summary	v
General Safety Instructions	v
Warnings, Cautions, and Notes.....	v
Hazardous Material Description, Precautions and First Aid	v
Toxicological Properties	vi
Precautionary Measures:	vi
Protective Equipment (Type).....	vi
First Aid Measures	vii
1 General Information and Specifications.....	1-1
1.1 General Information.....	1-1
1.2 Features	1-1
1.3 Specifications	1-2
2 Installation and Preparation for Use	2-1
2.1 General Information.....	2-1
2.2 Tools and Equipment Required.....	2-1
2.3 Foundation Requirements	2-2
2.4 Installation	2-2
2.4.1 Assemble Columns and Uprights.....	2-3
2.4.2 Installation of Overhead Beam	2-5
2.4.3 Installation of Power Unit.....	2-5
2.4.4 Installation of Equalizing Cables	2-5
2.4.5 Hydraulics Servicing.....	2-6
2.4.6 Electrical Hookup	2-6
2.5 Installation test.....	2-7
3 Operating Instructions.....	3-1
3.1 Safety Procedures	3-1
3.2 Daily Pre-Operation Check (8-Hours).....	3-1
3.3 Controls	3-2
3.4 Operation.....	3-2
3.4.1 Positioning Vehicle	3-2
3.4.2 Raising Vehicle.....	3-4
3.4.3 Lowering Vehicle	3-5
4 Maintenance and Troubleshooting	4-1
4.1 Maintenance	4-1
4.1.1 Owner/Employer Responsibilities.....	4-1
4.1.2 Periodic Maintenance Schedule.....	4-1
4.1.2.1 Daily Pre-Operation Check (8-Hours)	4-1
4.1.2.2 Weekly Maintenance (every 40-Hours)	4-1
4.1.2.3 Yearly Maintenance	4-2
4.1.2.4 Special Maintenance Tasks	4-2
4.2 Troubleshooting.....	4-2
4.2.1 Motor Does Not Operate	4-3
4.2.2 Motor Functions but Lift Will Not Rise	4-3
4.2.3 Oil Blows out Breather of Power Unit	4-3
4.2.4 Motor Hums and Will Not Run	4-4
4.2.5 Lift Jerks Going Up and Down.....	4-4
4.2.6 Oil Leaks	4-4

Table of Contents

4.2.7	Lift Makes Excessive Noise.....	4-4
5	Illustrated Parts Breakdown.....	5-1
5.1	Illustrated Parts Breakdown Information.....	5-1
5.2	Complete Parts Listing.....	5-10
5.2.1	Hardware Bag #1	5-10
5.2.2	Hardware Bag #2	5-11
5.2.3	Master (Complete) Parts Listing.....	5-11

List of Figures

<u>Figure</u>	<u>Page</u>
Figure 1-1. Symmetric/Asymmetric Configuration.....	1-1
Figure 1-2. Additional Features.....	1-2
Figure 1-3. Lift Dimensions	1-3
Figure 1-4. Radius of Lifting Arms.....	1-3
Figure 2-1. Foundation Requirements	2-2
Figure 2-2. Positioning Columns.....	2-3
Figure 2-3. Anchor Hole Drilling and Seating.....	2-4
Figure 2-4. Equalizing Cable Diagram	2-6
Figure 3-1. PRO-V10 Controls.....	3-3
Figure 3-2. Vehicle positioning.....	3-3
Figure 3-3. Positioning Lift Arms.....	3-4
Figure 5-1. Illustrated Parts Breakdown – Sheet 1 of 4	5-2
Figure 5-1. Illustrated Parts Breakdown – Sheet 2 of 4	5-4
Figure 5-1. Illustrated Parts Breakdown – Sheet 3 of 4	5-6
Figure 5-1. Illustrated Parts Breakdown – Sheet 4 of 4	5-8

List of Tables

<u>Table</u>	<u>Page</u>
Table 1-1. Basic PRO-V10 Specifications	1-2
Table 1-1. Basic PRO-V10 Specifications (Cont.).....	1-3
Table 3-1. PRO-V10 Controls	3-2
Table 5-1. Parts Listing – Page 1 of 4.....	5-3
Table 5-1. Parts Listing – Page 2 of 4.....	5-5
Table 5-1. Parts Listing – Page 3 of 4.....	5-7
Table 5-1. Parts Listing – Page 4 of 4.....	5-9
Table 5-1. Parts Listing – Page 4 of 4 (Cont.).....	5-10
Table 5-2. Hardware Bag #1	5-10
Table 5-2. Hardware Bag #1 (Cont.).....	5-11
Table 5-3. Hardware Bag #2.....	5-11
Table 5-4. Master (Complete) Parts Listing	5-11
Table 5-4. Master (Complete) Parts Listing (Cont.)	5-11
Table 5-4. Master (Complete) Parts Listing (Cont.)	5-12

Registration

READ THIS ENTIRE MANUAL BEFORE OPERATION BEGINS.

RECORD BELOW THE FOLLOWING INFORMATION WHICH IS LOCATED ON THE SERIAL NUMBER DATA PLATE

Serial No. _____

Model No. _____

Date of Installation _____

RECORD BELOW THE FOLLOWING CUSTOMER INFORMATION

Company Name _____

*Contact Person _____

Street Address _____

City _____

State _____

Phone _____

Fax _____

*Email _____

* Optional Fields

Warranty

Warranty

The structural components on your new automotive lift are warranted for five years on equipment. Hydraulic cylinders and power unit are warranted two years to the original purchaser, to be free of defects in material and workmanship.

The manufacturer shall repair or replace at their option for this period those parts returned to the factory freight prepaid, which prove after inspection to be defective.

This warranty only applies to the original purchaser of the equipment. This warranty does not extend to defects caused by ordinary wear, abuse, misuse, shipping damage, or damage as the result of improper maintenance.

This warranty is exclusive and in lieu of all other warranties expressed or implied.

In no event shall the manufacturer be liable for special, consequential or incidental damages for the breach or delay in performance of the warranty.

The manufacturer reserves the right to make design changes or add improvements to its product line without incurring any obligation to make such changes on product sold previously.

This warranty shall be governed under the laws of the state of Texas, and shall be subject to the exclusive jurisdiction of the Court in the state of Texas in the county of Tarrant.

This lift is a 10,000 lb. capacity, two-column lift. The safety system in this lift is attached to the back of the carriage to provide a single point release that saves time when operating. This lift is equipped with two heavy-duty cylinders to provide consistent power to the lift.

An electrical-hydraulic power unit included with the lift will provide up to 3000 psi of hydraulic pressure to actuate the cylinders.

Please read the Safety Procedures and operation instructions in this manual before operating the lift. Proper installation is very important. To minimize the chance of making an error in installation, please read this manual through carefully before beginning installation. Check with building owner and/or architect's building plans when applicable. The lift should be located on a relatively level floor with 4 in. thick, 3000 psi sufficiently cured concrete.

This is a vehicle lift installation / operation manual and no attempt is made or implied herein to instruct the user in lifting methods particular to an individual application. Rather, the contents of this manual are intended as a basis for operation and maintenance of the unit as it stands alone or as it is intended and anticipated to be used in conjunction with other equipment.

Proper application of the equipment described herein is limited to the parameters detailed in the specifications and the uses set forth in the descriptive passages. Any other proposed application of this equipment should be documented and submitted in writing to the factory for examination. The user assumes full responsibility for any equipment damage or personal injury that occurs as the result of alteration of the equipment described in this manual or any subsequent damages.

Safety Summary

General Safety Instructions

This summary describes physical and chemical processes that may cause injury or death to personnel, or damage to equipment if not properly followed. This safety summary includes general safety precautions and instructions that must be understood and applied during operation and maintenance to make sure that personnel safety and protection of equipment is observed. Prior to performing any task, the WARNINGS, CAUTIONS, and NOTES included in that task should be reviewed and understood.

Warnings, Cautions, and Notes

WARNINGS and CAUTIONS are used in this manual to highlight operating or maintenance procedures, practices, conditions or statements that are considered essential to protection of personnel (WARNING) or equipment (CAUTION). WARNINGS or CAUTIONS immediately precede the step or procedure to which they apply. NOTES are used in this manual to highlight operating or maintenance procedures, practices, conditions or statements that are not essential to the safeguarding of personnel or equipment. NOTES may precede or follow the step or procedure, depending on the information to be highlighted. The Headings used and their definitions are as follows.

WARNING

Highlights essential operating or maintenance procedure, practice, condition, statement, etc. that if not strictly observed, could result in injury to, or death of, personnel or long term health hazards.

CAUTION

Highlights essential operating or maintenance procedure, practice, condition, statement, etc. that if not strictly observed, could result in damage to, or destruction of equipment.

NOTE

Highlights essential operating or maintenance procedure, practice, condition, or statement.

Hazardous Material Description, Precautions and First Aid

This lift uses ISO Grade 32 AW, 46 or other good grade non-detergent hydraulic oil. Its toxicological properties, precautionary measures to take, and first aid measures are stated below.

Safety Summary

Toxicological Properties

Primary Route of Exposure:

Eyes
Skin
Inhalation

Effects of Overexposure

Acute:

Eyes: May cause minimal irritation, experienced as temporary discomfort.

Skin: Brief contact is not irritating. Prolonged contact, as with clothing wetted with material, may cause defatting of skin or irritation, seen as local redness with possible mild discomfort. Other than the potential skin irritation effects noted above, acute (short term) adverse effects are not expected from brief skin contact; see other effects, below, for information regarding potential long term effects.

Inhalation: Vapors or mist, in excess of permissible concentrations, or in unusually high concentrations generated from spraying, heating the material or as from exposure in poorly ventilated areas or confined spaces, may cause irritation of the nose and throat, headache, nausea, and drowsiness.

Ingestion: If more than several mouthfuls are swallowed, abdominal discomfort, nausea, and diarrhea may occur.

Chronic: No adverse effects have been documented in humans because of chronic exposure.

Sensitization Properties: Unknown.

Medical Conditions Aggravated by Over Exposure: Because of its defatting properties, prolonged and repeated skin contact may aggravate an existing dermatitis (skin condition).

Exposure Control for Total Product: None established for product. For Mineral oil mist: OSHA PEL-TWA 5 mg/m³, ACGIH TLV-TWA 5 mg/m³.

Other Remarks: Material from high pressure equipment, pinhole leaks, or high pressure line failure can penetrate the skin and, if not properly treated, can cause severe injury, including disfigurement, loss of function, or even require amputation of the affected area. To prevent such serious injury, immediate medical attention should be sought even if the injection injury appears to be minor.

Precautionary Measures:

Avoid prolonged breathing of vapor, mist, or gas.
Workers should wash exposed skin several times daily with soap and water.

Protective Equipment (Type)

Eye/Face Protection: Safety glasses, chemical type goggles, or face shield recommended to prevent eye contact.

Skin Protection: Workers should wash exposed skin several times daily with soap and water. Soiled work clothing should be laundered or dry-cleaned.

Respiratory Protection: Airborne concentrations should be kept to lowest levels possible. If vapor, mist or dust is generated and the occupational exposure limit of the product, or any component of the product, is exceeded, use appropriate NIOSH or MSHA approved air purifying or air-supplied respirator after determining the airborne concentration of the contaminant. Air supplied respirators should always be worn when airborne concentration of the contaminant or oxygen content is unknown.

Ventilation: Adequate to meet occupational exposure limits (see below).

Mineral oil mist: OSHA PEL-TWA 5 mg/m³, ACGIH TLV-TWA 5 mg/m³.

Procedures in Case of Accidental Release, Breakage or Leakage:

Ventilate area. Avoid breathing vapor. Wear appropriate personal protective equipment, including appropriate respiratory protection. Contain spill if possible. Wipe up or absorb on suitable material and shovel up. Prevent entry into sewers and waterways. Avoid contact with skin, eyes or clothing.

Waste Disposal Methods: Dispose of this product in accordance with local and/or national regulations.

Precautions to be taken in:

Handling: Minimum feasible handling temperatures should be maintained.

Storage: Periods of exposure to high temperatures should be minimized. Water contamination should be avoided.

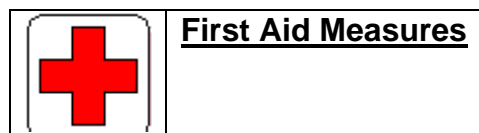

Eyes: Flush eyes with plenty of water for several minutes. Get medical attention if eye irritation persists.

Skin: Wash skin with plenty of soap and water for several minutes. Get medical attention if skin irritation develops or persists.

Ingestion: If more than several mouthfuls of this material are swallowed, give two glasses of water (16 oz.). Get medical attention.

Inhalation: If irritation, headache, nausea, or drowsiness occurs, remove to fresh air. Get medical attention if breathing becomes difficult or respiratory irritation persists.

Other Instructions: Remove and dry-clean or launder clothing soaked or soiled with this material before reuse. Dry cleaning of contaminated clothing may be more effective than normal laundering. Inform individuals responsible for cleaning of potential hazards associated with handling contaminated clothing.

Safety Summary

Note to Physician: High-pressure injection of material can cause severe injury. Failure to debride the wound of all residual material can result in disfigurement, loss of function, or may require amputation of the affected area

1 General Information and Specifications

1.1 General Information

This lift is a 10,000 lb. capacity, two-column lift. The safety system in this lift is attached to the back of the carriage to provide a single point release that saves time when operating. This lift is equipped with two heavy-duty direct-drive cylinders to provide consistent power to the lift.

An electrical-hydraulic power unit included with the lift will provide up to 3000 psi of hydraulic pressure to actuate the cylinders.

The lift can be configured with the lift arms in either a symmetric or an asymmetric mode as shown in figure 1-1.

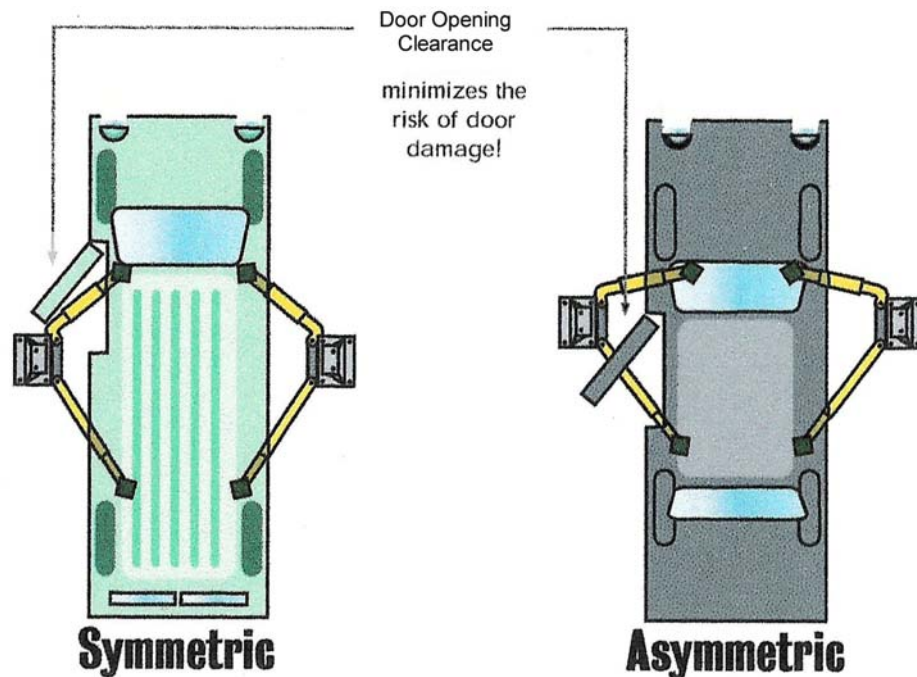

Figure 1-1. Symmetric/Asymmetric Configuration

1.2 Features

Additional features are shown in figure 1-2 on the following page.

General Information and Specifications

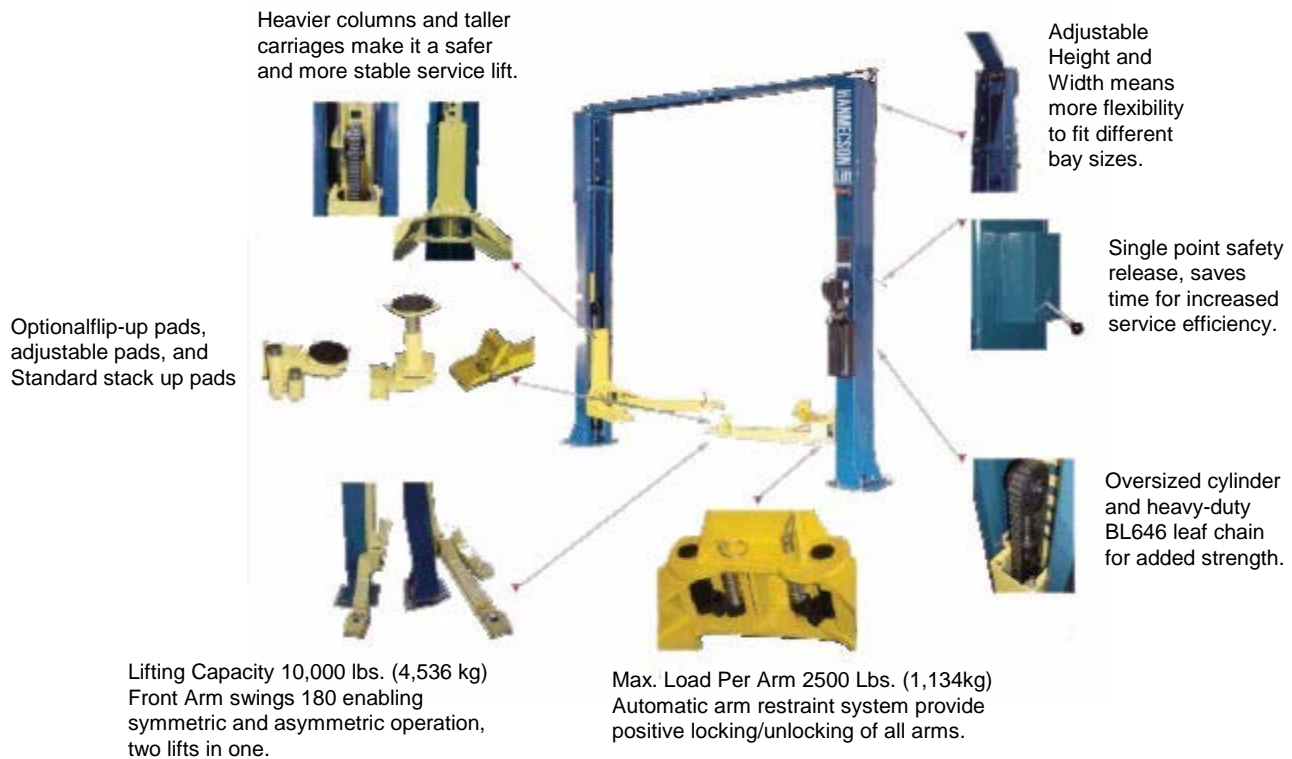

Figure 1-2. Additional Features

1.3 Specifications

The specifications are shown in the following table and in figure 1-3 on page 1-3. The radius of the lifting arms is shown in figure 1-4 on page 1-3.

Table 1-1. Basic PRO-V10 Specifications

Specification	Value
A. Rise Height	81-1/4 in., Highest position, with adapters
B. Adjustable Overall Height	141 in. Low Setup; 145 in. High Setup
C. Width Overall	137-3/8 in. Narrow Setup
D. Drive Through	98-5/8 in.
E. Floor to Overhead Switch	132-1/2 in. Low, 136-1/2 in. High
F. Front Arm Reach	Min.28-1/3 in./Max. 39-1/4 in.
G. Rear Arm Reach	Min.41 in./Max. 58-1/2 in.
H. Lifting Pad Height (Standard Pad)	Min. 5-3/16 in./ Max. 11-3/4 in.
Lifting Pad Height (Optional Flip-up Pad)	Min. 5-1/2 in./ Max. 9-1/2 in.
Lifting Pad Height (Optional Adjustable Pad)	Min. 8-1/2 in./ Max. 11 in.
L. Between Columns	110-3/4 in.
Lifting Capacity	10,000 Lbs (4,536 kg)
Max. Load Per Arm	2,500 Lbs per arm (1,134 kg)

Table 1-1. Basic PRO-V10 Specifications (Cont.)

Specification	Value
Lifting Chain	Heavy duty BL646
Cylinders	Dual, Heavy Duty, Oversized
Motor	2 HP
Voltage	208v – 230 vac
Speed of Rise	60 Seconds

*Optional low profile arms available to drop min. lifting pad height to 3-5/8 in.

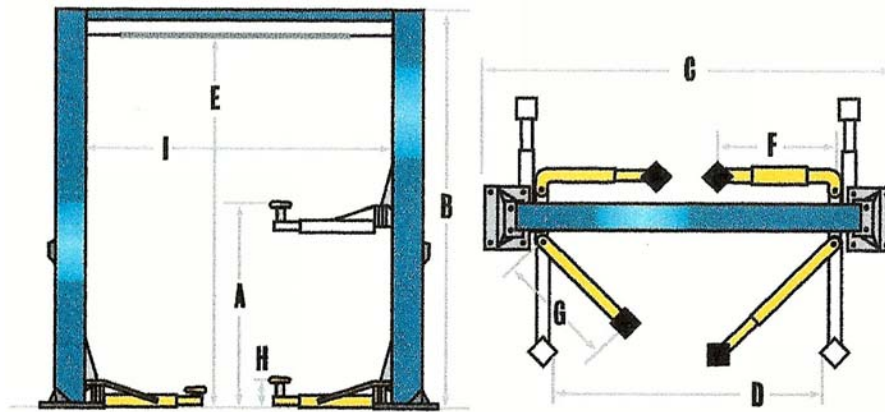

Figure 1-3. Lift Dimensions

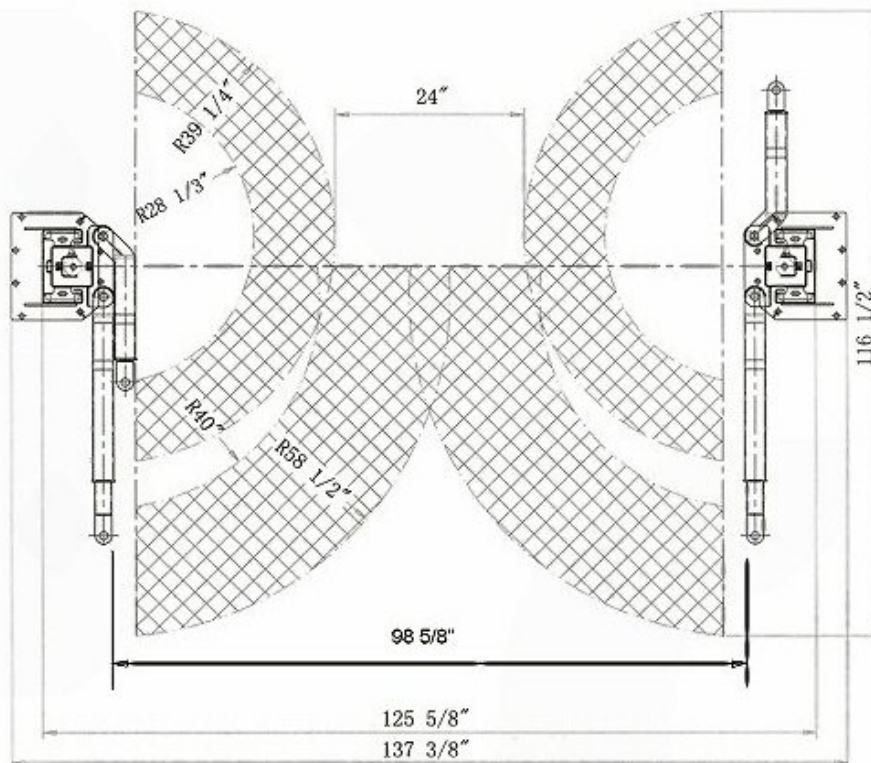

Figure 1-4. Radius of Lifting Arms

General Information and Specifications

The remaining chapters in this manual are as follows:

<u>Chapter/Title:</u>	<u>Page:</u>
2 - Installation and Preparation for Use	2-1
3 - Operating Instructions	3-1
4 - Maintenance and Troubleshooting	4-1
5 - Illustrated Parts Breakdown	5-1

2 Installation and Preparation for Use

2.1 General Information

1. Any freight damage must be noted on the freight bill before signing and reported to the freight carrier with a freight claim established. Identify the components and check for shortages. If shortages are discovered, contact Hanmecson International, Inc. immediately. Refer to chapter 5 for parts listing.
2. Consult building owner and / or architect's plans when applicable to establish the best lift location. The lift should be located on a relatively level floor with 4 in. minimum thickness, 3000-psi concrete slab that has been properly cured. **There can be no cracks in the slab within 36 in. of the base plate location, and no seams in the foundation within 6 in. of its' location! Remember: any structure is only as strong as the foundation on which it is located!**
3. This lift has two set-up dimensions as below:
 - a) Low set-up
 - 1) Between inside base plates 103 in.
 - 2) Inside columns 110-3/8 in.
 - 3) Overhead Clearance: 138-1/4 in.
 - 4) Ceiling Height Required: 142 in.
 - b) HIGH set-up
 - 1) Between inside base plates 103 in.
 - 2) Inside columns 110-3/8 in.
 - 3) Overhead Clearance: 142-3/4 in.
 - 4) Ceiling Height Required: 146 in.

NOTE

Check for ceiling clearance first to see how high the lift can be set up in your bay.

2.2 Tools and Equipment Required

The installation of this lift is relatively simple and can be accomplished by two men in a few hours. The following tools and equipment are needed:

- Appropriate lifting equipment
- AW 32, 46 or other good grade Non-Detergent Hydraulic Oil SAE-10 (12 quarts)
- Chalkline and 12' Tape Measure
- Rotary Hammer Drill with 3/4 in. Drill Bit. Core Drill Rebar Cutter recommended
- Transit and a 4' Level
- Sockets and Open Wrench set, 1/2 in. thru 1-1/2 in. (1-1/8 in. for 3/4 in. Anchors)
- Locking Pliers, 8mm Socket Head Wrench

2.3 Foundation Requirements

The foundation requirements are listed below:



Columns are supported only by anchoring in the floor. DO NOT install on asphalt or other similar unstable surface. Failure to follow the requirements of the following step could result in damage to, or destruction of equipment.

The foundation has to be long enough for the vehicles to be supported, wide enough to provide support for the lift, and the concrete shall have compression strength of at least 3,000 PSI and a minimum thickness of 4 in. in order to achieve a minimum anchor embedment of 3-¼ in. When using the standard supplied ¾ in. x 5-½ in. long anchors, if the top of the anchor exceeds 2-¼ in. above the floor grade you **DO NOT** have enough embedment. Figure 2-1 provides an overview of the foundation sizing requirements.

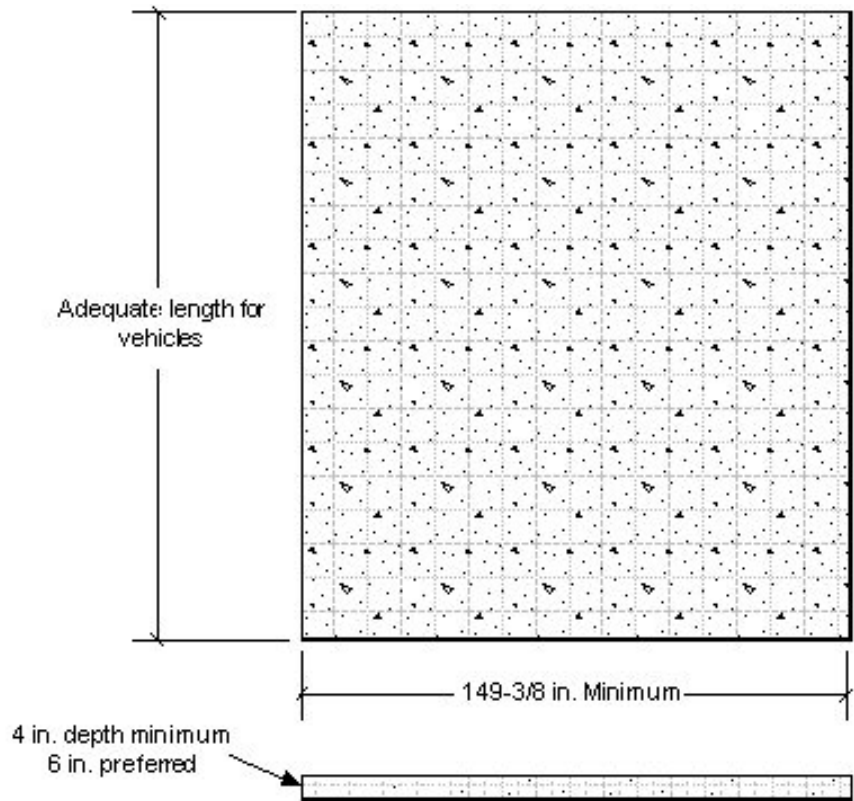

Figure 2-1. Foundation Requirements

2.4 Installation

Install as given in the following paragraphs.

2.4.1 Assemble Columns and Uprights

Assemble the columns and uprights according to the following steps:

1. After unloading the lift, place it near the intended installation location.
2. Remove the shipping bands and packing materials from the lift. The power unit and cylinders will be unpacked from the top.
3. Open the wrapping from the upper column and carefully remove the parts from inside. Unbolt the column from the shipping brackets. Unbolt the up-rights (Item # 20 in the parts list) from the columns and assemble it to the column (Item # 19 in the parts list). See figure 5-1 sheet 4 on page 5-8.
4. Unpack the cylinders and open the oil port on each cylinder by unscrewing the black plastic cap. Move the carriage up about 20 in. to 25 in. Next, carefully slide the cylinder inside from the bottom of the carriage. The oil port will face the backside of the column and the notch on the bottom of the cylinder will fit into the hole in the center of the base plate.
5. Position the columns facing each other 103 in. inside base plates (see figure 2-2). Square the columns by measuring diagonally from corner points on base plates (within 1/4 in.).

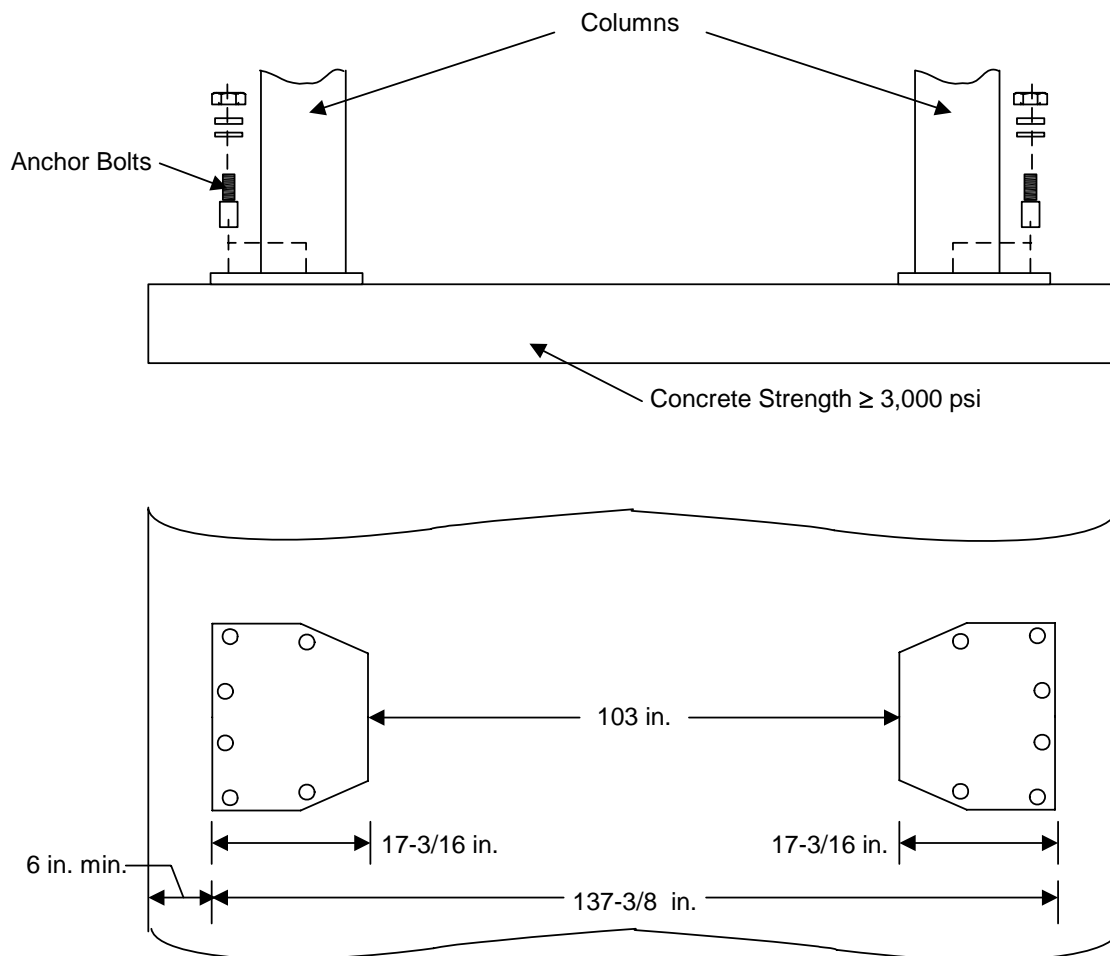

Figure 2-2. Positioning Columns

Installation and Preparation for Use

6. Secure the columns to the foundation as follows (refer to figure 2-3 on page 2-4):
 - a) Using a 3/4 in. diameter concrete drill, drill the anchor holes in the concrete for the main side column, installing anchors as you go. Use a concrete hammer drill with a carbide tip solid drill bit the same diameter as the anchor, 3/4 in. (.775 to .787 inches diameter). **Do not** use excessively worn bits or bits which have been incorrectly sharpened. Refer to figure 2-3 Detail A on page 2-6.
 - 1) Keep the drill in a perpendicular line while drilling.
 - 2) Use a block of wood or rubber mallet to drive anchor bolts into the concrete.
 - 3) Drill to a minimum depth of 4 in. to make sure maximum holding power is obtained. Drilling thru concrete (recommended) will allow the anchor to be driven thru the bottom if the threads are damaged.
 - 4) Let the drill do the work. Do not apply excessive pressure. Lift the drill up and down occasionally to remove residue to reduce binding.
 - 5) Drill the hole to depth equal to the length of anchor.
 - 6) For better holding power blow dust from the hole (.Refer to figure 2-3 Detail B).

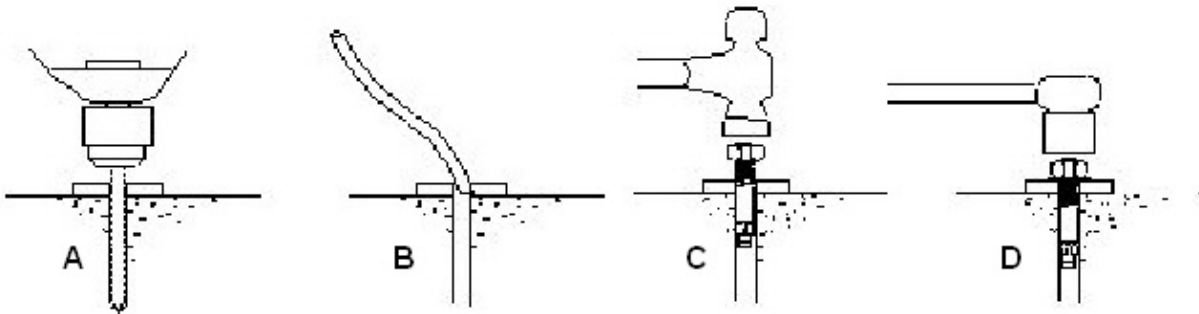

Figure 2-3. Anchor Hole Drilling and Seating

7. Using a level, check column for side-to-side plumb and front-to-back plumb. If needed, use horseshoe shims provided by placing shims underneath the base plate and around the anchor bolt. This will prevent bending the column bottom plates (Shim thickness should not exceed 1/2 in.). Tighten 3/4 in. anchor bolts to 150 ft-lbs. of torque.
8. Using a tape measure, measure from back corner of the base to the opposite back corner to make sure the legs are square. After confirming dimensions, drill and install the anchors on the other side leg.
9. Level the second column as described in step #7.

2.4.2 Installation of Overhead Beam

Install the overhead beam as follows:

1. Install the overhead cross beam. This cross beam has two pieces, to be connected by six (6) bolts in the center of the beam. Be sure to bolt them together by installing the bolts from inside the cross beam out. This is to avoid interference with the cable when operating the lift. Refer to figure 5-1 sheet 4 on page 5-8.
2. Connect the safety release cable (Item # 47 on the parts list - refer to figure 5-1 sheet 3 on page 5-6) between the two latches as shown on figure 5-1 sheet 3 on page 5-6. Check the tension of the cable is tight. Pull the single point release handle several times and check the tension again by making sure both latches release at the same time when the handle is pulled.

2.4.3 Installation of Power Unit

Install the power unit as follows.

1. Refer to figure 5-1 sheet 4 on page 5-8, item 30, and mount the power unit on the main side leg to the power unit bracket using the four 5/16 in. bolts and nuts. Install the "T" fitting with o-ring on the power unit, and then install the 6 in. pipe into the backside of the main column cylinder (power unit side). Connect the 90-degree hydraulic fitting on the other end of the 6 in. pipe. Connect the short hydraulic hose to one side of the "T" fitting at power unit, then run the hose down the column and connect to the fitting on the base of cylinder. Connect the long hydraulic hose to the other side of the "T" fitting. Place the hose across over the overhead beam to the opposite column, then down the side and connect to the fitting on the other column cylinder.

2.4.4 Installation of Equalizing Cables

Connect the equalizing cables (Item #48 on parts list) as shown in figure 2-4 on page 2-6 by doing the following. Do not tighten at this stage of assembly:

1. The cable stud that connects to the front right corner of the carriage should be connected first by pulling the stud through the carriage hole and up where it is easy to be held by locking pliers.
2. Pull the stud back into place after threading at least ½ in. of the stud past locknut.
3. Connect the other ends to the rear right corners of the carriage with at least ½ in. of thread showing past lock nut (cables run on inside of carriage). It may be necessary to manually raise both carriages above the cylinder to provide enough space to use the locking pliers. Make sure the carriage is set in the **LOCK** position.
4. Adjust the carriage cable tension. This is accomplished by tightening the carriage adjustment nut on top of each carriage. The left post carriage nut adjusts the right column carriage, and the right column carriage nut adjusts the left column carriage. Adjust each cable to approximately ½ in. side-to-side play. Check the latch releases to make sure the carriage is still engaged in the appropriate latch.
5. Install the half moon gear locks (item 2, figure 5-1 Sheet 4 on page 5-8) on each swing arm (USA side up). Position the swing arms on the carriages using the included 1 1/2" diameter pins (2 short for front arms and 2 long for rear arms). Check for proper engagement of the arm lock – the rack on the lock should fully engage the gear on the arm.

Installation and Preparation for Use

2.4.5 Hydraulics Servicing

Remove the vent plug from the power unit and fill the reservoir. Use a Ten Weight (SAE-10) non-foaming, non-detergent hydraulic fluid (Texaco HD46 or equal). The unit will hold approximately twelve quarts of fluid.

WARNING

Failure to comply with this warning could result in death or injury. The wiring must comply with local code. In the following step have a certified electrician make the electrical hook-up to the power unit. Protect each circuit with time delay fuse or circuit breaker rated at 208v-230v single phase. 60 Hz 30 amp. Motor cannot run on 50 Hz without a physical change to motor

2.4.6 Electrical Hookup

Make the Electrical hookup to the power unit; 220V Single Phase. It is recommended that a 220 Volt, 30 Amp twist lock plug be installed in the power line just ahead of the power unit. Use wire capable of supporting a 30-amp circuit.

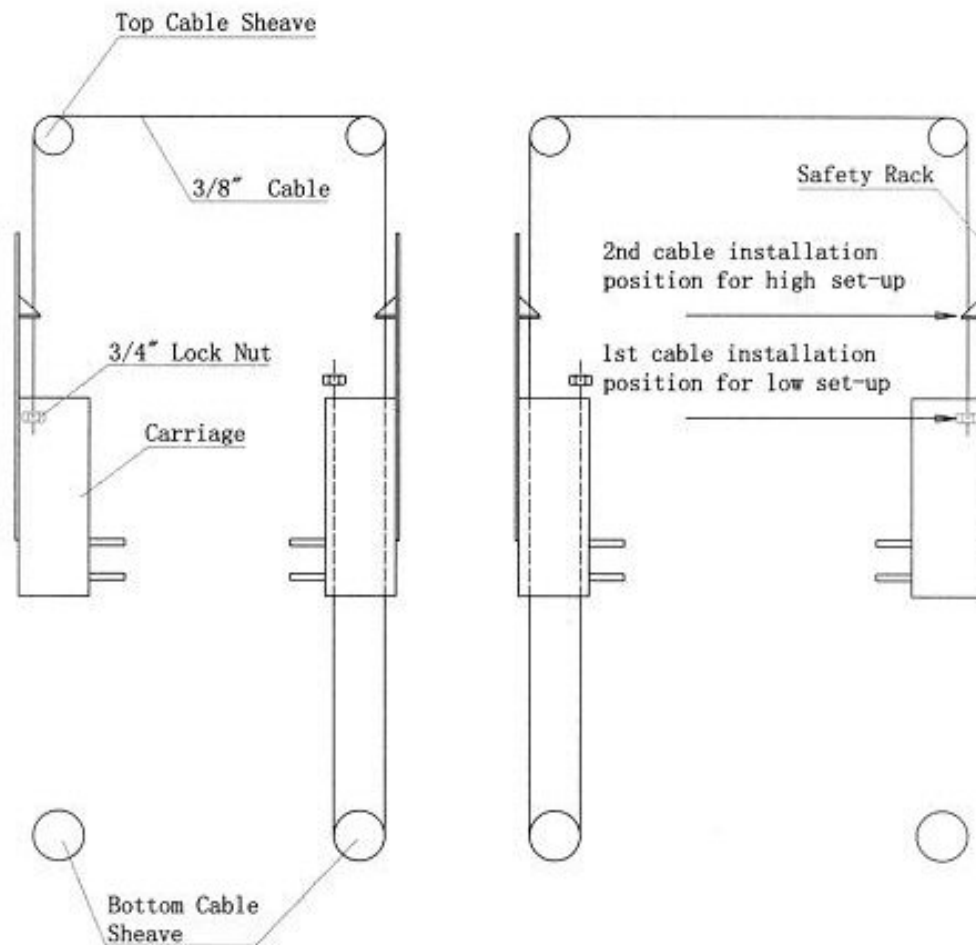

Figure 2-4. Equalizing Cable Diagram

2.5 Installation test

Test the Lift operation by doing the following:

CAUTION

Failure to comply with this caution could result in damage to the lift. Do not place any vehicle on the lift at this time.

6. Cycle the lift up and down several times to make sure latches engage properly and all air is removed from the system. To lower the lift, first raise the lift to clear the latches and then pull down the safety release handle to lower the lift. If latches function out of sync, tighten the cable on the latch that engages first.

This page intentionally left blank.

3 Operating Instructions

3.1 Safety Procedures

WARNING

Failure to adhere to the following can result in death or injury, or damage to the equipment and vehicle. All personnel will be made aware of this warning and trained in the use and care of the lift.

1. Never allow unauthorized persons to operate lift. Thoroughly train new employees in the use and care of lift.
2. Caution - the power unit operates at high pressure.
3. Remove passengers before raising vehicle.
4. Prohibit unauthorized persons from being in shop area while lift is in use.
5. Total lift capacity is 10,000-lbs. with 2,500-lbs. per swivel pad. Do not exceed this capacity.
6. Prior to lifting vehicle, walk around the lift and check for any objects that might interfere with the operation of lift and safety latches; tools, air hoses, shop equipment.
7. When approaching the lift with a vehicle, center the vehicle between the columns so that the tires will clear the swing arms easily. Slowly drive the vehicle up between the posts. Have someone outside the vehicle guide the driver.
8. Always lift vehicle using all four pads.
9. Never use lift to raise one end or one side of vehicle.
10. Raise vehicles about 3 in. and check stability by rocking.
11. Prior to lowering vehicle, walk around the lift and check for any objects that might interfere with the operation of lift and safety latches; tools, air hoses, shop equipment. Swing the arms out and slowly drive the vehicle out. Have someone outside the vehicle guide the driver.
12. Always lock the lift before going under the vehicle. Never allow anyone to go under the lift when raising or lowering.

3.2 Daily Pre-Operation Check (8-Hours)

NOTE

Occupational Safety and Health Administration (OSHA) and the American National Standards Institute (ANSI) require users to inspect lifting equipment at the start of every shift. These and other periodic inspections are the responsibility of the user.

WARNING

Failure to perform the daily pre-operational check can result in expensive property damage, lost production time, serious personal injury, and even death. The safety latch system must be checked and working properly before the lift is put to use.

The daily pre-operational check consists of the following:

1. Check safety lock audibly and visually while in operation
2. Check safety latches for free movement and full engagement with rack.
3. Check hydraulic connections, and hoses for leakage.
4. Check chain connections - bends, cracks-and loose links.
5. Check cable connections- bends, cracks-and looseness.
6. Check for frayed cables in both raised and lowered position.
7. Check snap rings at all rollers and sheaves.
8. Check bolts, nuts, and screws and tighten if needed.
9. Check wiring & switches for damage.
10. Keep base plate free of dirt, grease or any other corrosive substances.
11. Check floor for stress cracks near anchor bolts.
12. Check swing arm restraints.

3.3 Controls

The controls are located on the column as shown in figure 3-1 in page 3-3 and their use and function given in table 3-1 below.

Table 3-1. PRO-V10 Controls

Item No.	Type	Purpose
1	Safety release handle	Used to release safety latches when lowering vehicle.
2	Push button switch	Controls electrical power to the power unit. Push to turn-on, and push again to turn-off the power unit.
3	Lower lever	Used to relieve hydraulic pressure when pressed down.
4	Reservoir cap	Cap for the power unit fluid reservoir. Remove to add fluid.

3.4 Operation

Operate the lift as given in the following paragraphs.

3.4.1 Positioning Vehicle

When approaching the lift with a vehicle, center the vehicle between the columns so that the tires will clear the lift arms easily. Refer to figure 3-2 on page 3-3. Slowly drive the vehicle up between the posts. Have some one outside the vehicle guide the driver.

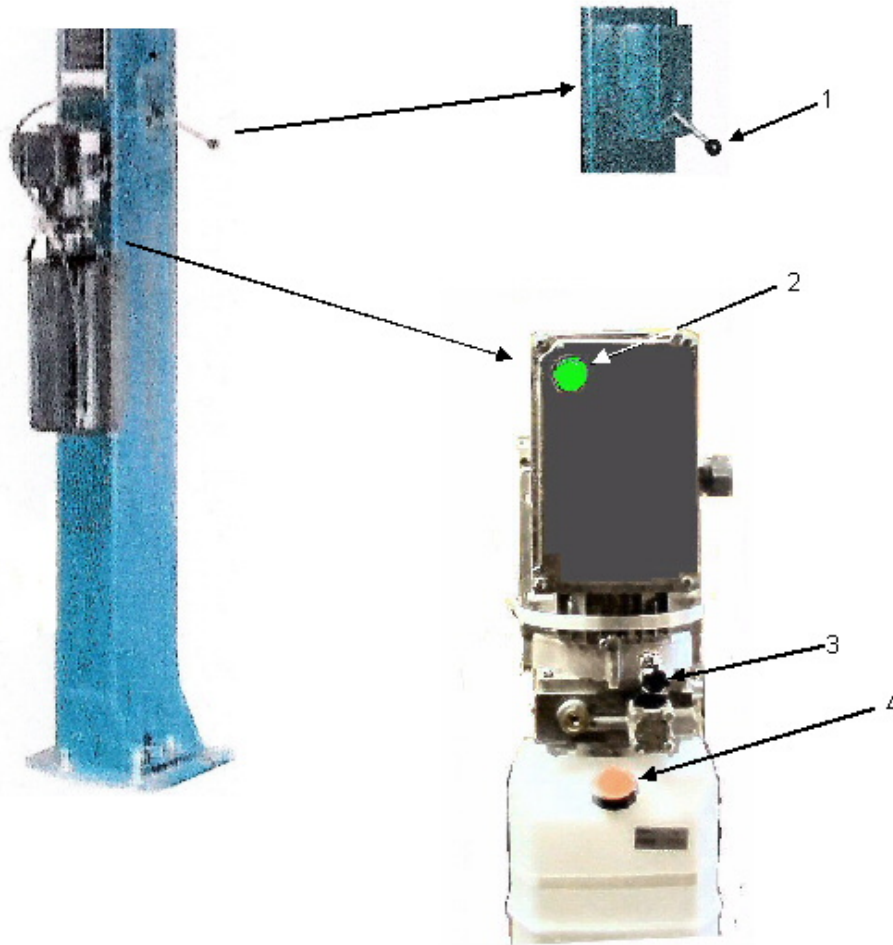

Figure 3-1. PRO-V10 Controls

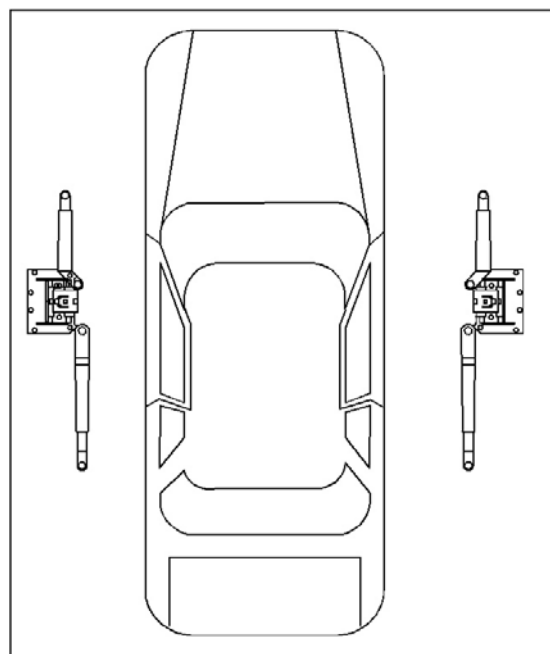

Figure 3-2. Vehicle positioning

3.4.2 Raising Vehicle

WARNING

Failure to adhere to the following can result in death or injury, or damage to the equipment and vehicle. All personnel will be made aware of this warning and trained in the use and care of the lift. Remove passengers before raising vehicle and prohibit unauthorized persons from being in shop area while lift is in use. Do not exceed the weight limitation of 10,000-lbs. Total and 2,500-lbs. Per swivel pad. Always lift the vehicle using all four pads.

1. Selecting the proper configuration for the vehicle to be lifted (symmetric/asymmetric) position the lift arms as shown in figure 3-3. Make sure the lifting pads are in a proper and safe position to support the vehicle.

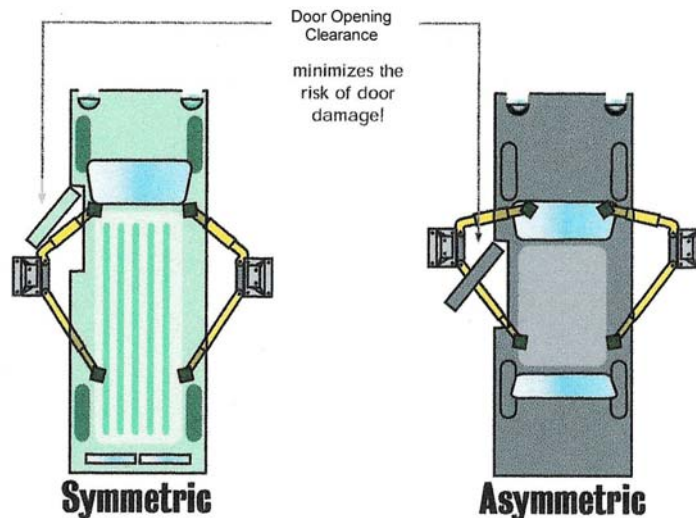

Figure 3-3. Positioning Lift Arms

2. Prior to lifting vehicle, walk around the lift and check for any objects that might interfere with the operation of lift and safety latches; tools, air hoses, shop equipment.
3. Raise vehicle about 3 in. by pressing the button on the power unit and check stability by rocking.
4. Raise the lift by pressing the button on the power unit until the vehicle is at the desired height and the safety latches are properly seated.

NOTE

The safety latch mechanism will 'trip over' when the lift raises and drop into each latch stop. To lock the lift you must press the lower lever to relieve the hydraulic pressure and let the latch set tight in a lock position.

WARNING

Failure to adhere with the following step could result in death or injury as well as damage to the lift and vehicle. Always lock the lift before going under the vehicle. Never allow anyone to go under the lift when raising or lowering

5. Lock the lift by pressing the lower lever to relieve the hydraulic pressure and let the latch set tight in a lock position.

3.4.3 Lowering Vehicle

Lower the vehicle as follows:

WARNING

Failure to adhere with this warning could result in death or injury as well as damage to the lift and vehicle. Prior to lowering vehicle, walk around the lift and check for any objects that might interfere with the operation of lift and safety latches; tools, air hoses, shop equipment

1. Raise the lift until the latches clear the safety racks in both sides.
2. Pull down and hold the safety release handle.

CAUTION

Failure to comply with this caution could result in damage to the lift and/or vehicle. Lower the lift slowly under heavy loads.

3. Press the lowering lever at the power unit to lower the lift.
4. Swing the arms out and slowly drive the vehicle out. Have some one outside the vehicle guide the driver.

This page intentionally left blank.

4 Maintenance and Troubleshooting

4.1 Maintenance

4.1.1 Owner/Employer Responsibilities

The owner/employer is responsible for, and will do the following:

1. Shall establish procedures to periodically maintain, inspect and care for the lift in accordance with the manufactures recommended procedures to make sure its' continued operation is safe.
2. Shall provide necessary lockout / tag outs of energy sources per ANSI Z244.1 – 1982 before beginning any lift repairs.
3. Shall not modify the lift in any manner without prior written consent of the manufacturer.
4. Shall display the operating instructions, “Lifting It Right” and “Safety Tips” supplied with the lift in a conspicuous location in the lift area convenient to the operator.
5. Shall make sure that lift operators are instructed in the proper and safe use and operation of the lift using the manufacturer’s instructions and “Lift It Right” and “Safety Tips” supplied with the lift.

4.1.2 Periodic Maintenance Schedule

The periodic maintenance given in the following paragraphs is the suggested minimum requirements and minimum intervals; accumulated hours or monthly period, which ever comes sooner.

WARNING

Failure to heed this warning can result in death or serious injury, or damage to equipment. If you hear a noise not associated with normal lift operation, or, if there is any indication of impending lift failure - **CEASE OPERATION IMMEDIATELY!** - Inspect, correct and/or replace parts as required.

Periodic maintenance is to be performed on a daily, weekly, and yearly basis as given in the following paragraphs.

4.1.2.1 Daily Pre-Operation Check (8-Hours)

This daily pre-operational check is shown in the Operation Chapter as it is performed on a daily basis before use of the lift. Refer to page 3-1.

4.1.2.2 Weekly Maintenance (every 40-Hours)

On a weekly basis, perform the following checks:

1. Check anchor bolts torque to 150 ft-lbs for the ¾ in. anchor bolts. **Do not use an impact wrench.**
2. Check floor for stress cracks near anchor bolts.
3. Check hydraulic oil level.

Maintenance and Troubleshooting

4. Check and tighten bolts, nuts, and screws.
5. Check cylinder pulley assembly for free movement or excessive wear on cylinder yoke or pulley pin.
6. Check cable pulley for free movement and excessive wear.

4.1.2.3 Yearly Maintenance

The following shall be accomplished on a yearly basis

1. Lubricate chain
2. Grease rub blocks and column surface contacting rub blocks
3. Change the hydraulic fluid - good maintenance procedure makes it mandatory to keep hydraulic fluid clean. No hard fast rules can be established; - operating temperature, type of service, contamination levels, filtration, and chemical composition of fluid should be considered. If operating in dusty environment shorter interval may be required.

4.1.2.4 Special Maintenance Tasks

The following items should only be performed by a trained maintenance expert.

1. Replacement of hydraulic hoses.
2. Replacement of chains and rollers.
3. Replacement of cables and sheaves.
4. Replacement or rebuilding air and hydraulic cylinders as required.
5. Replacement or rebuilding pumps / motors as required.
6. Checking of hydraulic cylinder rod and rod end (threads) for deformation or damage.

NOTE

Relocating or changing components may cause problems. Each component in the system must be compatible; an undersized or restricted line will cause a drop in pressure. All valve, pump, and hose connections should be sealed and/or capped until just prior to use. Air hoses can be used to clean fittings and other components. However, the air supply must be filtered and dry to prevent contamination. Most important - cleanliness - contamination is the most frequent cause of malfunction or failure of hydraulic equipment.

4.2 Troubleshooting

The common problems that may be encountered and their probable causes are covered in the following paragraphs:

<u>Paragraph:</u>	<u>Problem:</u>	<u>Page:</u>
4.2.1	Motor Does Not Operate	4-3
4.2.2	Motor Functions But Lift Will Not Rise	4-3
4.2.3	Oil Blows Out Breather Of Power Unit	4-3
4.2.4	Motor Hums and Will Not Run	4-4
4.2.5	Lift Jerks Going Up and Down	4-4
4.2.6	Oil Leaks	4-4
4.2.7	Lift Makes Excessive Noise	4-4

4.2.1 Motor Does Not Operate

Failure of the motor to operate is normally caused by one of the following:

1. Breaker or fuse blown.
2. Motor thermal overload tripped. Wait for overload to cool.
3. Faulty wiring connections; call electrician.
4. Defective up button call electrician for checking.

4.2.2 Motor Functions but Lift Will Not Rise

If the motor is functioning, but the lift will not rise do the following in the order given:

1. A piece of trash is under check valve. Push handle down and push the up button at the same time. Hold for 10-15 seconds. This should flush the system.
2. Check the clearance between the plunger valve of the lowering handle. There should be 1/16 in.
3. Remove the check valve cover and clean ball and seat.

WARNING

Failure to properly relieve pressure in the following step can cause injury to personnel. This lift uses ISO Grade 32 AW, 46 or other good grade non-detergent hydraulic oil at a high hydraulic pressure. Be familiar with its toxicological properties, precautionary measures to take, and first aid measures as stated in the Safety Summary before performing any maintenance with the hydraulic system.

4. Oil level too low. Oil level should be just under the vent cap port when the lift is down. Relieve all hydraulic pressure and add oil as required.

4.2.3 Oil Blows out Breather of Power Unit

If oil blows out of the breather of the power unit, take the following actions:

WARNING

Failure to properly relieve pressure in the following step can cause injury to personnel. Failure to properly relieve pressure in the following step can cause injury to personnel. This lift uses ISO Grade 32 AW, 46 or other good grade non-detergent hydraulic oil at a high hydraulic pressure. Be familiar with its toxicological properties, precautionary measures to take, and first aid measures as stated in the Safety Summary before performing any maintenance with the hydraulic system.

1. Oil reservoir overfilled. Relieve all pressure and siphon out hydraulic fluid until at a proper level
2. Lift lowered too quickly while under a heavy load. Lower the lift slowly under heavy loads.

Maintenance and Troubleshooting

4.2.4 Motor Hums and Will Not Run

If the motor hums but fails to run, take the following actions:

1. Impeller fan cover is dented. Remove cover and straighten.
2. Lift overloaded. Remove excessive weight from lift

WARNING

The voltages used in the lift can cause death or injury to personnel. In the following steps, make sure that a qualified electrician is used to perform maintenance

3. Faulty wiring..... Call electrician
4. Bad capacitor..... Call electrician
5. Low voltage..... Call electrician

4.2.5 Lift Jerks Going Up and Down

If the lift jerks while going up and down, it is usually a sign of air in the hydraulic system. Raise lift all the way to top and return to floor. Repeat 4-6 times. **Do not let this overheat power unit.**

4.2.6 Oil Leaks

Oil leak causes at the power unit and cylinders are normally caused by the following. Take the actions shown to fix the problem:

WARNING

Failure to heed this warning could cause serious injury or damage to the lift. Failure to properly relieve pressure in the following step can cause injury to personnel. This lift uses ISO Grade 32 AW, 46 or other good grade non-detergent hydraulic oil at a high hydraulic pressure. Be familiar with its toxicological properties, precautionary measures to take, and first aid measures as stated in the Safety Summary before performing any maintenance with the hydraulic system. Make sure that pressure is fully relieved before checking oil levels, loosening any hydraulic lines, or removing any cylinders.

1. Power unit: if the power unit leaks hydraulic oil around the tank-mounting flange check the oil level in the tank. The level should be two inches below the flange of the tank. A screwdriver can be used as a "dipstick".
2. Rod end of the cylinder: the rod seal of the cylinder is out. Rebuild or replace the cylinder.
3. Breather end of the cylinder: the piston seal of the cylinder is out. Rebuild or replace the cylinder.

4.2.7 Lift Makes Excessive Noise

Excessive noise from the lift is normally caused by the following. Take the corrective actions shown.

Maintenance and Troubleshooting

1. Leg of the lift is dry and requires grease.
2. Cylinder pulley assembly or cable pulley assembly is not moving freely.
3. May have excessive wear on pins or cylinder yoke.

This page intentionally left blank.

5 Illustrated Parts Breakdown

This chapter consists of the illustrated parts breakdown in as detailed in paragraph 5-1, and a complete parts listing in paragraph 5-2.

NOTE

Use the complete parts listing in paragraph 5-2 to perform inventory before assembly of the lift.

5.1 Illustrated Parts Breakdown Information.

This paragraph consists of the detailed illustrations and parts listings for the Model PRO-V10 10,000 Pound Two-Column Automotive Lift. Certain parts may be shown on more than one figure in order to illustrate their relationship with other components shown in the figure. The illustrations are shown on the left-hand pages with their corresponding parts listing shown on the right-hand pages.

NOTE

The part quantities shown are the totals for that part contained within the entire lift. Therefore, the quantities shown may be greater than what is shown on an individual sheet of the IPB illustrations

Illustrated Parts Breakdown

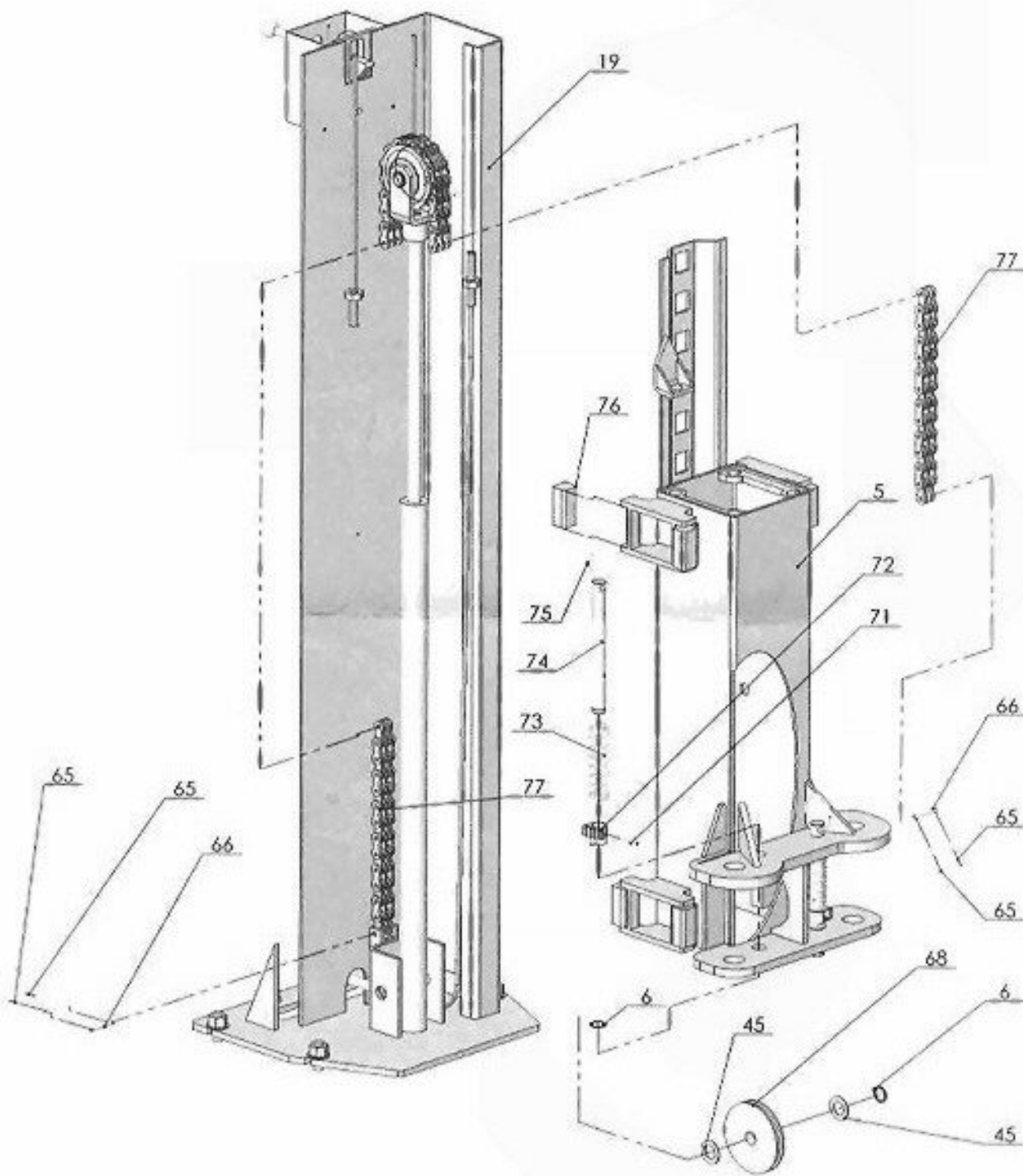

Figure 5-1. Illustrated Parts Breakdown – Sheet 1 of 4

Table 5-1. Parts Listing – Page 1 of 4

Item	Drawing Number	Name/Description	QTY
5	30500-5100	CARRIAGE	2
6	GB8942-86	SNAP RING	14
19	30500-1000	COLUMNS	2
45	30400-1005C	FLAT WASHERS	10
65	GB91-86	SPLIT PIN	8
66	30500-9405	CHAIN PIN	4
68	52005	4-3/4 in. CABLE SHEAVE	2
71	GB897-86	ROLL PIN	4
72	30500-5202 A	GEAR RACK	4
73	30500-5200-4	SPRING	4
74	30500-5200-1	ARM LOCK PIN	4
75	30500-5200-3	RING	4
76	30400-5020	RUB BLOCKS	16
77	BL646*125P	LEAF CHAIN	2

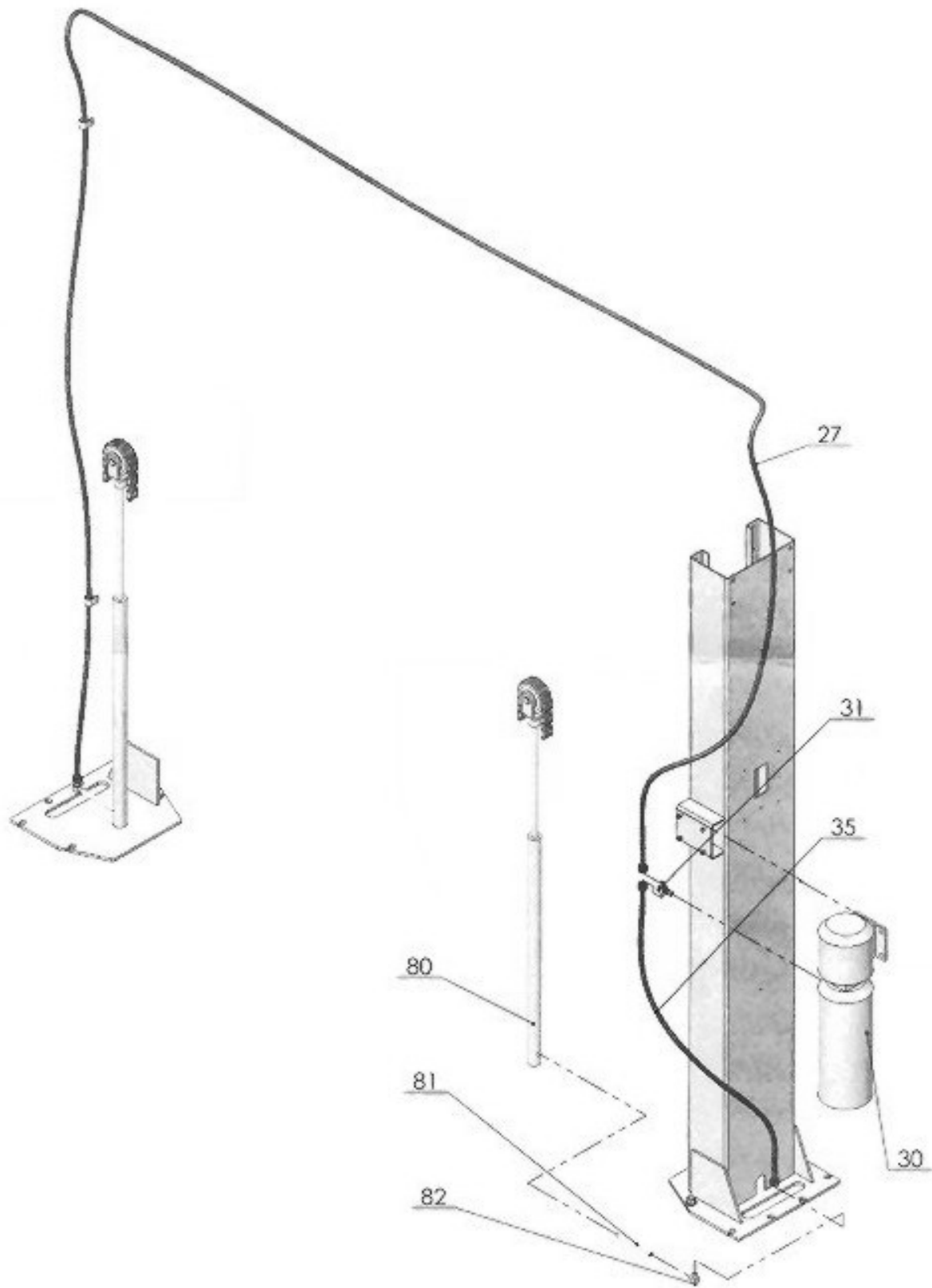

Figure 5-1. Illustrated Parts Breakdown – Sheet 2 of 4

Table 5-1. Parts Listing – Page 2 of 4

Item	Drawing Number	Name/Description	QTY
27	30500-9101	HYDRAULIC HOSES	1
30	WT-3	HYDRAULIC POWER UNIT	1
31	30400-9051YZ	T FITTING	1
35	30500-9102	HYDRAULIC HOSES	1
80	YG04-9100	CYLINDERS	2
81	30400-9052YZ	PIPE	2
82	30500-9100	ELBOW FITTINGS	2

Illustrated Parts Breakdown

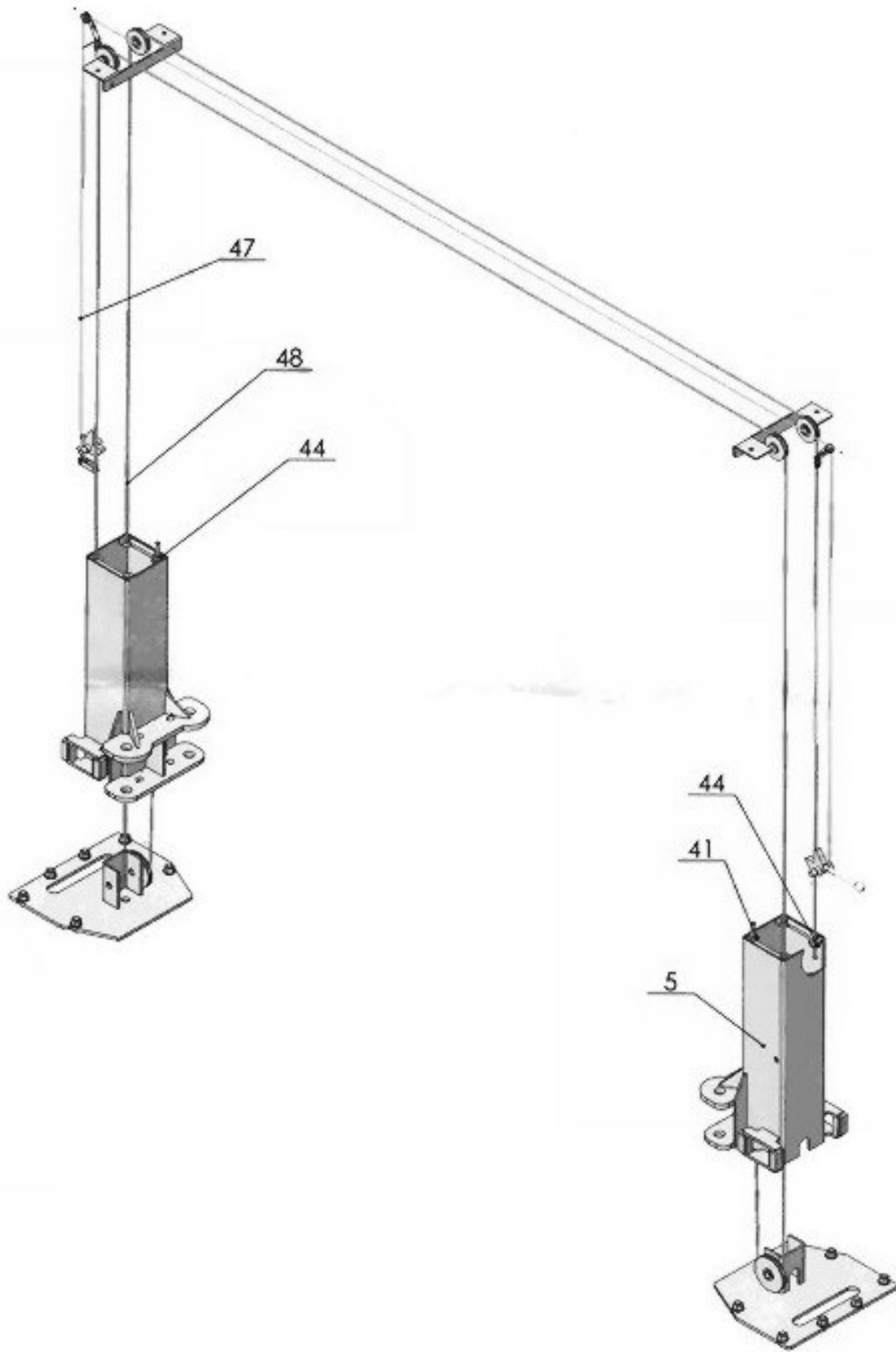

Figure 5-1. Illustrated Parts Breakdown – Sheet 3 of 4

Table 5-1. Parts Listing – Page 3 of 4

Item	Drawing Number	Name/Description	QTY
5	30500-5100	CARRIAGE	2
41	GB95-85-20mm	20 MM FLAT WASHERS	8
44	GB/T889-1986	NYLON LOCK NUT	4
47		2.5 MM X300 in. CABLE	1
48	30500-9200	3/8 in. EQUALIZING CABLE	2

Illustrated Parts Breakdown

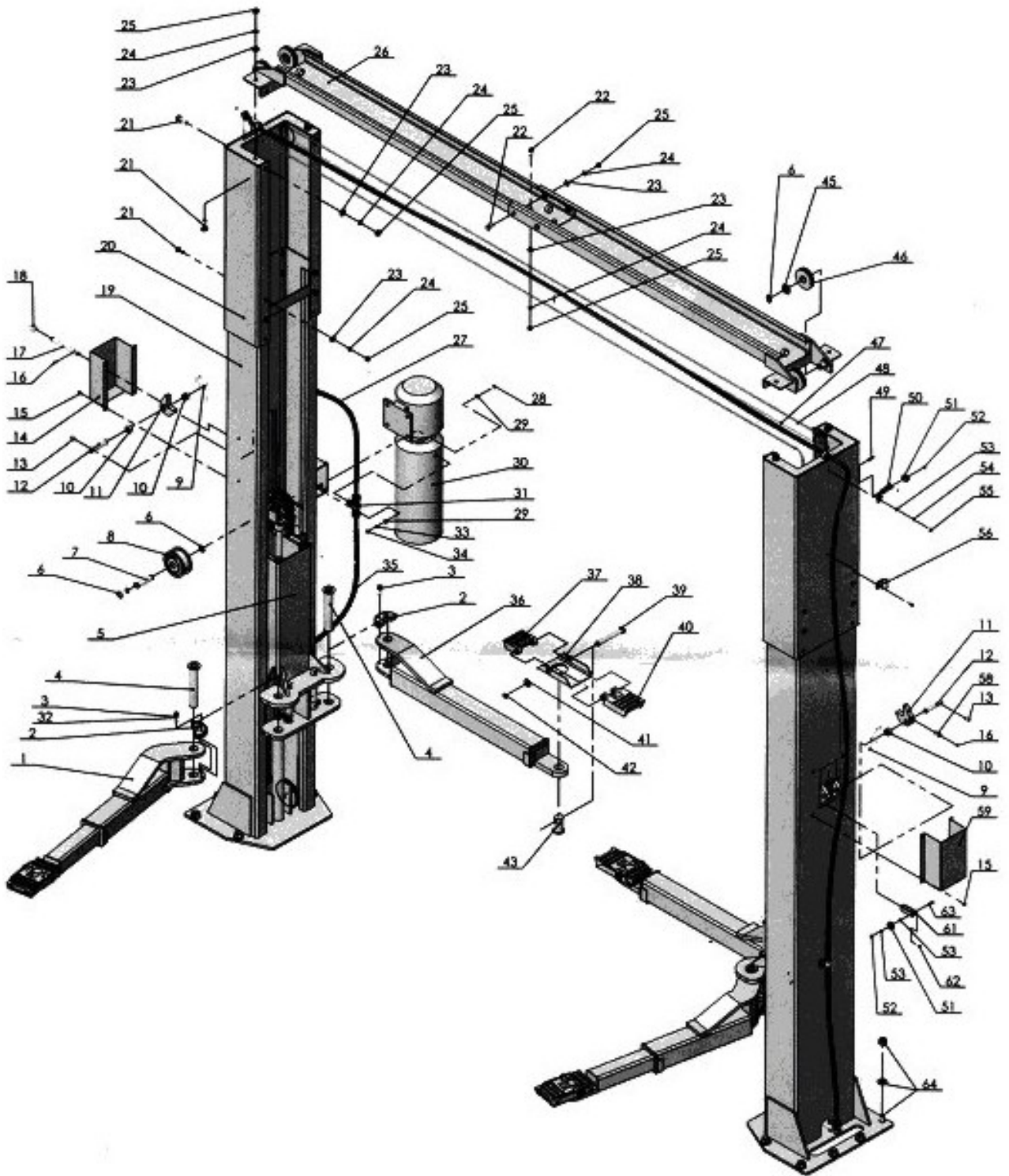

Figure 5-1. Illustrated Parts Breakdown – Sheet 4 of 4

Table 5-1. Parts Listing – Page 4 of 4

Item	Drawing Number	Name/Description	QTY
1	30500-7000	FRONT ARM	2
2	30500-6011 A	HALF MOON GEAR, ARM LOCK	4
3	GB5781-86- M10 X 30	BOLT M10 X 30 (MM)	8
4	30500-5300	SWING ARM PIN	4
5	30500-5100	CARRIAGE	2
6	GB8942-86	SNAP RING	14
7	30500-9403	CHAIN SHEAVE SHAFT	2
8	91816	CHAIN SHEAVE	2
9	30500-5001 B -10	LATCH SPRING	2
10	30500-5001 B -07	SLEEVE	4
11	30500-5001 B -03	SAFETY LATCH	2
12	30500-5001 B -09	SHAFT FOR LATCH	2
13	GB71-85	SET SCREW	2
14	30500-8000-1A	SAFETY LATCH COVER	1
15	GB67-85- M6 X 16	SCREW M6 X 16 (MM)	8
16	GB71-85- M6 X 16	SCREW M6 X 16 (MM)	2
17	30500-5001 B -12	SAFETY RELEASE HANDLE	1
18		PLASTIC KNOB	1
19	30500-1000	COLUMNS	2
20	30500-2000	UP-RIGHTS	2
21	GB5781-86- M12 X 40	BOLTS M12 X 40 (MM)	24
22	GB5781-86 M12 X 25	BOLTS M12 X 25 (MM)	6
23	GB95-85-6	FLAT WASHERS	60
24	GB93-87-6	LOCK WASHERS	30
25	GB41-86-12	NUT 12 MM	30
26	30500-3000	OVERHEAD CROSS BEAM	1
27	30500-9101	HYDRAULIC HOSES	1
28	GB5781-86-M8 X 25	BOLTS M8 X 25 (MM)	4
29	GB95-85-8	8 MM WASHER	8
30	WT-3	HYDRAULIC POWER UNIT	1
31	30400-9051YZ	T FITTING	1
32	GB93-87	LOCK WASHERS	8
33	GB93-87-8	8 MM LOCK WASHERS	4
34	GB41-86-8	8MM NUTS	4
35	30500-9102	HYDRAULIC HOSES	1
36	30500-6000	LONG ARMS	2
37	30500-6100-2	3 in. SHORT FLIP UPS	4
38	30500-6100-5	LIFT PAD CHANNEL	4
39	30500-6100-4	PAD SHAFT	4
40	30500-6100-1	6 in. LONG FLIP UPS	4
41	GB95-85-20	20 MM FLAT WASHERS	8
42	GB8942-86	SNAP RING	4
43	30500-6100-3	PIN, LIFTING PAD	4
44	GB/T889-1986	NYLON LOCK NUT	4
45	30400-1005C	FLAT WASHERS	10
46	52007	3.62 in. CABLE SHEAVE	4
47		2.5 MM X300 in. CABLE	1
48	30500-9200	3/8 in. EQUALIZING CABLE	2
49	GB70-85- M6 X 25	BOLTS M6 X 25 (MM)	2

Illustrated Parts Breakdown

Table 5-1. Parts Listing – Page 4 of 4 (Cont.)

Item	Drawing Number	Name/Description	QTY
50	30500-8000-2-1	CABLE SHEAVE BRACKET	2
51	30500-8000-2-2	CABLE SHEAVE	3
52	GB41-86-6	NUT 6 MM	3
53	GB95-85-6	FLAT WASHERS 6 MM	14
54	GB93-87-6	LOCK WASHERS	12
55	GB5781-86- M6 X 16	BOLTS M6 X 16 (MM)	4
56		HYDRAULIC HOSES CLIPS	10
58	30500-5001 B -11	SAFETY OPERATING ROD	1
59	30500-8001-1B	SAFETY LATCH COVER	1
61	30500-8000-3-1	CABLE SHEAVE BRACKET	1
62	GB70-85- M6 X 20	BOLTS M6 X 20 (MM)	1
63	GB5781-86- M6 X 30	BOLTS M6 X 30 (MM)	1
64	WG-1	ANCHOR BOLT 3/4 in. X 5-1/2 in.	12

5.2 Complete Parts Listing

The lift consists of two hardware bags and the remainder of the lift parts. When inventorying the hardware bags **do not** mix the parts in the two bags together. Return them to the original bags. The master or complete parts' listing is shown in paragraph 5.2.3.

5.2.1 Hardware Bag #1

Hardware Bag # 1 contains the items listed in table 5-2. Item numbers shown are those as shown on the master parts listing.

Table 5-2. Hardware Bag #1

Item	Drawing Number	Name/Description	QTY
2	30500-6011 A	HALF MOON GEAR, ARM LOCK	4
3	GB5781-86- M10 X 30	BOLT M10 X 30 (MM)	8
15	GB67-85- M6 X 16	SCREW M6 X 16 (MM)	8
21	GB5781-86- M12 X 40	BOLTS M12 X 40 (MM)	24
22	GB5781-86- M12 X 25	BOLTS M12 X 25 (MM)	6
23	GB95-85	FLAT WASHERS	60
24	GB93-87	LOCK WASHERS	30
25	GB41-86-12	NUT 12 MM	30
28	GB5781-86- M8 X 25	BOLTS M8 X 25 (MM)	4
29	GB95-85-8	8 MM WASHER	8
31	30400-9051YZ	T FITTING	1
32	GB93-87	LOCK WASHERS	8
33	GB93-87-8	8 MM LOCK WASHERS	4
34	GB41-86-8	8MM NUTS	4
41	GB95-85-20	20 MM FLAT WASHERS	8
44	GB/T889-1986	NYLON LOCK NUT	4
47		2.5 MM X300 in. CABLE	1
52	GB41-86-6	NUT 6 MM	3
53	GB95-85-6	FLAT WASHERS 6 MM	14
54	GB93-87	LOCK WASHERS	12
55	GB5781-86- M6 X 16	BOLTS M6 X 16 (MM)	4

Table 5-2. Hardware Bag #1 (Cont.)

Item	Drawing Number	Name/Description	QTY
56		HYDRAULIC HOSES CLIPS	10
81	30400-9052YZ	PIPE	2
82	30500-9100	ELBOW FITTINGS	2
		Wire Clevis	4
		SCREW M6 X 8 (MM)	10

5.2.2 Hardware Bag #2

Hardware Bag # 2 contains the items listed in table 5-3. Item numbers shown are those as shown on the master parts listing.

Table 5-3. Hardware Bag #2

Item	Drawing Number	Name/Description	QTY
64		ANCHOR BOLT 3/4 in. X 5-1/2 in.	12
		FLAT WASHER, 3/4 in.	12
		LOCK WASHER, 3/4 in.	12
		NUT, 3/4 in.	12

5.2.3 Master (Complete) Parts Listing

The master or complete parts listing is given in table 5-4 below.

NOTE

In the following table use figure 5-1, sheets 1 through 4 shown on pages 5-2, 5-4, 5-6, and 5-8 to identify parts. Items marked with a single asterisk (*) are located in Hardware Bag # 1 and those marked with a double asterisk (**) in Hardware Bag #2 as listed on page 5-11.

Table 5-4. Master (Complete) Parts Listing

Item	Drawing Number	Name/Description	QTY
*2	30500-6011 A	HALF MOON GEAR, ARM LOCK	4
*3	GB5781-86- M10 X 30	BOLT M10 X 30 (MM)	8
4	30500-5300	SWING ARM PIN	4
5	30500-5100	CARRIAGE	2
6	GB8942-86	SNAP RING	14
7	30500-9403	CHAIN SHEAVE SHAFT	2
8	91816	CHAIN SHEAVE	2
9	30500-5001 B -10	LATCH SPRING	2
10	30500-5001 B -07	SLEEVE	4
11	30500-5001 B -03	SAFETY LATCH	2
12	30500-5001 B -09	SHAFT FOR LATCH	2
13	GB71-85	SET SCREW	2
14	30500-8000-1A	SAFETY LATCH COVER	1
*15	GB67-85- M6 X 16	SCREW M6 X 16 (MM)	8
16	GB71-85- M6 X 16	SCREW M6 X 16 (MM)	2
17	30500-5001 B -12	SAFETY RELEASE HANDLE	1
18		PLASTIC KNOB	1

Table 5-4. Master (Complete) Parts Listing (Cont.)

Illustrated Parts Breakdown

Item	Drawing Number	Name/Description	QTY
19	30500-1000	COLUMNS	2
20	30500-2000	UP-RIGHTS	2
*21	GB5781-86- M12 X 40	BOLTS M12 X 40 (MM)	24
*22	GB5781-86- M12 X 25	BOLTS M12 X 25 (MM)	6
*23	GB95-85-12	FLAT WASHERS	60
*24	GB93-87-12	LOCK WASHERS	30
*25	GB41-86-12	NUT 12 MM	30
26	30500-3000	OVERHEAD CROSS BEAM	1
27	30500-9101	HYDRAULIC HOSES	1
*28	GB5781-86- M8 X 25	BOLTS M8 X 25 (MM)	4
*29	GB95-85-8	8 MM WASHER	8
30		HYDRAULIC POWER UNIT	1
*31	30400-9051YZ	T FITTING	1
*32	GB93-87	LOCK WASHERS	8
*33	GB93-87-8	8 MM LOCK WASHERS	4
*34	GB41-86-8	8MM NUTS	4
35	30500-9102	HYDRAULIC HOSES	1
36	30500-6000	LONG ARMS	2
37	30500-6100-2	3 in. SHORT FLIP UPS	4
38	30500-6100-5	LIFT PAD CHANNEL	4
39	30500-6100-4	PAD SHAFT	4
40	30500-6100-1	6 in. LONG FLIP UPS	4
*41	GB95-85-20	20 MM FLAT WASHERS	8
42	GB8942-86	SNAP RING	4
43	30500-6100-3	PIN, LIFTING PAD	4
*44	GB/T889-1986	NYLON LOCK NUT	4
45	30400-1005C	FLAT WASHERS	10
46	52007	3.62 in. CABLE SHEAVE	4
*47		2.5 MM X300 in. CABLE	1
48	30500-9200	3/8 in. EQUALIZING CABLE	2
49	GB70-85- M6 X 25	BOLTS M6 X 25 (MM)	2
50	30500-8000-2-1	CABLE SHEAVE BRACKET	2
51	30500-8000-2-2	CABLE SHEAVE	3
*52	GB41-86-6	NUT 6 MM	3
*53	GB95-85-6	FLAT WASHERS 6 MM	14
*54	GB93-87	LOCK WASHERS	12
*55	GB5781-86- M6 X 16	BOLTS M6 X 16 (MM)	4
*56		HYDRAULIC HOSES CLIPS	10
58	30500-5001 B -11	SAFETY OPERATING ROD	1
59	30500-8001-1B	SAFETY LATCH COVER	1
61	30500-8000-3-1	CABLE SHEAVE BRACKET	1
62	GB70-85- M6 X 20	BOLTS M6 X 20 (MM)	1
63	GB5781-86- M6 X 30	BOLTS M6 X 30 (MM)	1
**64		ANCHOR BOLT 3/4 in. X 5-1/2 in.	12
**		FLAT WASHER, 3/4 in.	12
**		LOCK WASHER, 3/4 in.	12
**		NUT, 3/4 in.	12
65	GB91-86	SPLIT PIN	8
66	30500-9405	CHAIN PIN	4

Table 5-4. Master (Complete) Parts Listing (Cont.)

Illustrated Parts Breakdown

Item	Drawing Number	Name/Description	QTY
68	52005	4-3/4 in. CABLE SHEAVE	2
71	GB897-86	ROLL PIN	4
72	30500-5202 A	GEAR RACK	4
73	30500-5200-4	SPRING	4
74	30500-5200-1	ARM LOCK PIN	4
75	30500-5200-3	RING	4
76	30400-5020	RUB BLOCKS	16
77	BL646*125P	LEAF CHAIN	2
80	YG04-9100	CYLINDERS	2
*81	30400-9052YZ	PIPE	2
*82	30500-9100	ELBOW FITTINGS	2
*		Wire Clevis	4
*		SCREW M6 X 8 (MM)	10

This page intentionally left blank.